



MODEL CWP 300/K PROFI MOBILE GL

COOLING OUTPUT OF UP TO 200 L/HOUR

ADVANTAGES AND FUNCTIONAL CHARACTERISTICS OF THE CWP LINDR LINE:

CZECH UP YOUR BEER
COOLING AND DISPENSING SYSTEMS

The mobility of models from the CWP MOBIL GREEN LINE series allows the coolers to be fitted with dispense tower with an advertising medallion and drip tray, for use at larger events, fairs, sports events, etc. Model CWP 300 MOBIL is fitted with a drain valve for easy draining of water from the device and with a water gauge for checking the water level.

| CWP MOBIL GREEN LINE

The coolers from the CWP Mobil series prepare high-quality and evenly chilled beverages thanks to a design without thermal shock using a sufficiently long stainless coil. Your beverage will be fully chilled within 30-40 minutes from turning on the device. Temperature can be smoothly regulated with immediate impact on the temperature of the dispensed beverage.



CWP (Contact Water Power) – unique construction of the thermal block that combines the advantages of contact cooler and water based cooler in one. The evaporator is in direct contact with the beverage tubing and is able to respond immediately to increase beverage dispensing rate. The time needed to cool the beverage is only 30-40 minutes from turning the device on.

GREEN LINE – LINDR GREEN LINE

technology is environmentally friendly thanks to the use of eco-friendly refrigerant R-290. We have introduced an energy saving system in the production. Thanks to this design, each product achieves **20% higher energy efficiency and 20% lower energy consumption.**

LINDR COOLING TECHNOLOGY – always more powerful than its electric input power.

CONSTRUCTION AND SERVICING – the modern arrangement of LINDR cooling technology ensures ease of access for potential servicing and maintenance.

PERFORMANCE, QUALITY, SIZE – the best performance/ quality/ size ratio.

✓ **KEG PRESSURISATION** - CWP MOBIL 300/K PROFI is fitted with a unique system of two built-in, silent, high-quality air compressors with high output. The compressors are fitted with a noise dampener and a molecule filter for intake air and allow individual pressure regulation in 1 – 3.6 bar range.

✓ **DESIGN** - models from the CWP 200/ 300/ 300/K PROFI MOBIL GREEN LINE series are fitted with a dispense tower with medallions and backlit panel for advertising.

✓ **GREEN LINE** – all models from the CWP series are fully in GREEN LINE design.

✓ **EQUIPMENT AND MOBILITY** – includes a built-in drip tray with waste outlet and wheels for ease of transport, thermostat allowing smooth and precise temperature regulation, cooling coil and speedfit fittings.

TECHNICAL PARAMETERS

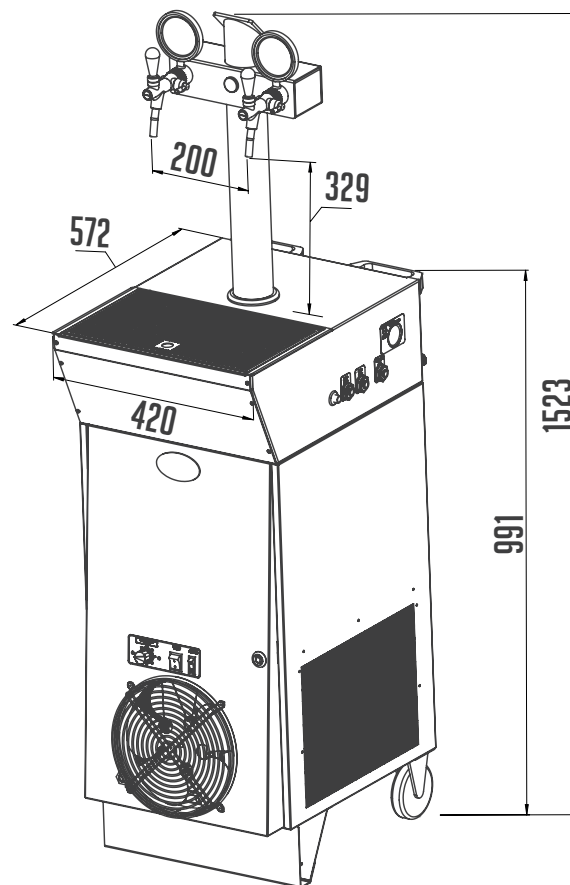

PRODUCT MODEL	CWP 300/ K PROFI MOBIL 2x Tap GL
COOLING POWER OF THE COMPRESSOR (HP)	1
COOLING POWER OF THE COMPRESSOR (W)	2300
MAXIMUM COOLING CAPACITY TO 0°C / TK 45°C (L/HOUR)	200
CONTINUOUS COOLING PERFORMANCE (L/HOUR)	180
THERMAL GRADIENT ΔT (°C)	10
ICE BANK (KG)	0-5
DISPLACEMENT OF RECIRCULATION PUMP (M)	6
AIR COMPRESSOR (BAR)	YES, REGULATION 1,0-3,6
NUMBER OF COOLED BEVERAGES (PCS)	2
NUMBER/ LENGTH OF COOLING COILS (M)	2/ 40
POWER (W)	1311
AMPERAGE (A)	5,70
NET WEIGHT (KG)	71,0
TYPE OF REFRIGERANT	R290
VOLTAGE	220-240V 50HZ~1
CONNECTION BEER/ AIR - SPEEDFIT FITTINGS	3/8, 5/16

AVAILABLE CUSTOM MODIFICATION OPTIONS	YES
CHOICE OF TAPS	✓
CHOICE OF DISPENSING TOWER	✓
POWER CABLE PLUG	✓

Note
 Selected models are also available in 115 V/60 Hz or 220 V/60 Hz voltage.
 Other custom modifications are also available (contact us).